

APPENDIX A: TRAFFIC COUNTS



Type of peak hour being reported: Intersection Peak

Method for determining peak hour: Total Entering Volume

LOCATION: Pulehu Rd -- Ho'okele St
 CITY/STATE: Kahului, HI

QC JOB #: 13803903
 DATE: Tue, May 17 2016

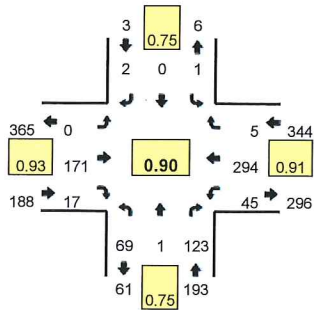

Peak-Hour: 7:30 AM -- 8:30 AM
 Peak 15-Min: 7:45 AM -- 8:00 AM

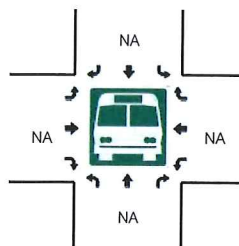
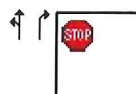
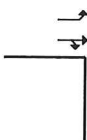
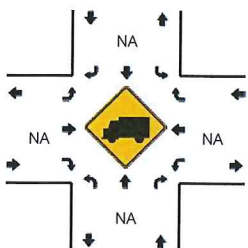
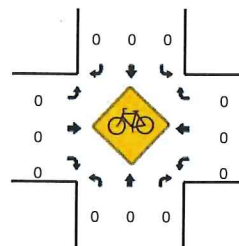
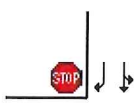
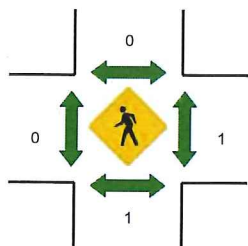
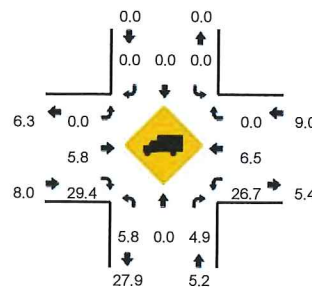

15-Min Count Period Beginning At	Pulehu Rd (Northbound)				Pulehu Rd (Southbound)				Ho'okele St (Eastbound)				Ho'okele St (Westbound)				Total	Hourly Totals
	Left	Thru	Right	U	Left	Thru	Right	U	Left	Thru	Right	U	Left	Thru	Right	U		
6:00 AM	11	1	9	0	0	0	0	0	0	15	2	0	10	41	0	0	89	
6:15 AM	9	0	13	0	0	0	0	0	0	15	4	0	9	38	0	0	88	
6:30 AM	12	1	16	0	1	0	0	0	0	20	5	0	7	44	2	0	108	
6:45 AM	18	0	25	0	0	0	0	0	0	32	2	0	11	56	0	0	144	429
7:00 AM	22	0	20	0	1	0	0	0	0	28	6	0	8	52	1	0	138	478
7:15 AM	21	0	25	0	0	1	0	0	0	31	4	0	11	52	0	1	146	536
7:30 AM	17	0	31	0	0	0	0	0	0	34	1	0	8	74	0	0	165	593
7:45 AM	22	1	45	0	0	0	1	0	0	35	6	0	12	79	0	1	202	651
8:00 AM	19	0	21	0	0	0	0	0	0	48	5	0	9	66	1	0	169	682
8:15 AM	11	0	26	0	1	0	1	0	0	54	5	0	15	75	4	0	192	728
8:30 AM	13	0	16	0	0	0	0	0	1	48	7	0	12	54	0	0	151	714
8:45 AM	18	0	25	0	0	0	0	0	1	45	6	0	14	60	2	0	171	683
Peak 15-Min Flowrates	Northbound				Southbound				Eastbound				Westbound				Total	
	Left	Thru	Right	U	Left	Thru	Right	U	Left	Thru	Right	U	Left	Thru	Right	U		
All Vehicles	88	4	180	0	0	0	4	0	0	140	24	0	48	316	0	4	808	
Heavy Trucks	0	0	4		0	0	0		0	8	12		12	28	0		64	
Pedestrians			0				0			0				0			0	
Bicycles	0	0	0		0	0	0		0	0	0		0	0	0		0	
Railroad																		
Stopped Buses																		

Comments:

LOCATION: Ho'okele St -- Hana Hwy
 CITY/STATE: Kahului, HI

QC JOB #: 13803901
 DATE: Tue, May 17 2016

Peak-Hour: 7:15 AM -- 8:15 AM
 Peak 15-Min: 7:15 AM -- 7:30 AM

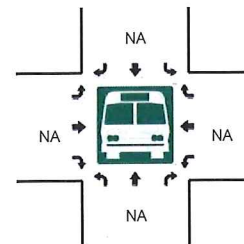
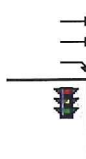
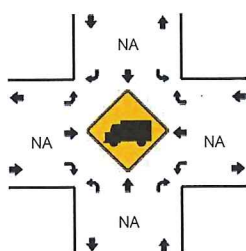
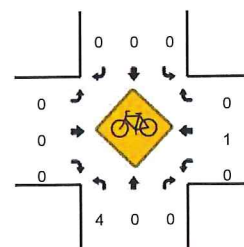
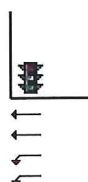
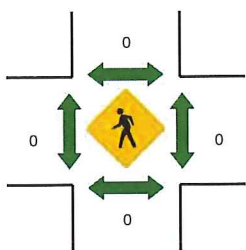
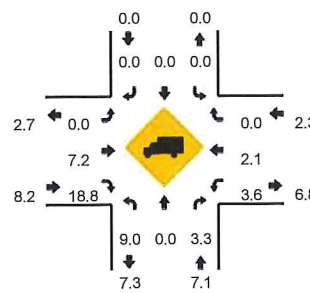
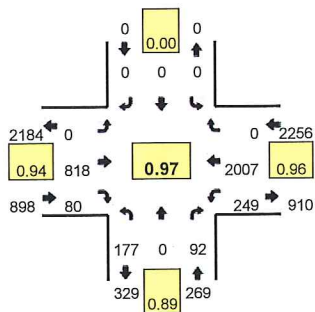

15-Min Count Period	Ho'okele St (Northbound)				Ho'okele St (Southbound)				Hana Hwy (Eastbound)				Hana Hwy (Westbound)				Total	Hourly Totals
	Left	Thru	Right	U	Left	Thru	Right	U	Left	Thru	Right	U	Left	Thru	Right	U		
Beginning At																		
6:00 AM	16	0	7	0	0	0	0	0	0	79	15	0	36	249	0	0	402	
6:15 AM	17	0	13	0	0	0	0	0	0	113	14	0	37	388	0	0	582	
6:30 AM	23	0	8	0	0	0	0	0	0	139	12	0	43	433	0	0	658	
6:45 AM	39	0	18	0	0	0	0	0	0	156	15	0	54	541	0	0	823	2465
7:00 AM	24	0	24	0	0	0	0	0	0	215	21	0	43	486	0	0	813	2876
7:15 AM	41	0	19	0	0	0	0	0	0	225	17	0	52	532	0	0	886	3180
7:30 AM	33	0	23	0	0	0	0	0	0	199	19	0	61	513	0	0	848	3370
7:45 AM	57	0	26	0	0	0	0	0	0	193	22	0	69	478	0	0	845	3392
8:00 AM	46	0	24	0	0	0	0	0	0	201	22	0	67	484	0	0	844	3423
8:15 AM	50	0	33	0	0	0	0	0	0	202	36	0	51	356	0	0	728	3265
8:30 AM	34	0	25	0	0	0	0	0	0	192	20	1	42	334	0	0	648	3065
8:45 AM	47	0	27	0	0	0	0	0	0	179	34	0	46	356	0	0	689	2909
Peak 15-Min Flowrates	Northbound				Southbound				Eastbound				Westbound				Total	
All Vehicles	164	0	76	0	0	0	0	0	0	900	68	0	208	2128	0	0	3544	
Heavy Trucks	20	0	4		0	0	0		0	40	20		0	44	0		128	
Pedestrians	0	0	0		0	0	0		0	0	0		0	0	0		0	
Bicycles	0	0	0		0	0	0		0	0	0		0	0	0		0	
Railroad																		
Stopped Buses																		

Comments:

Type of peak hour being reported: Intersection Peak

Method for determining peak hour: Total Entering Volume

LOCATION: Pulehu Rd -- Hansen Rd
CITY/STATE: Kahului, HI

QC JOB #: 13803905
DATE: Thu, May 19 2016

Peak-Hour: 7:00 AM -- 8:00 AM
Peak 15-Min: 7:15 AM -- 7:30 AM

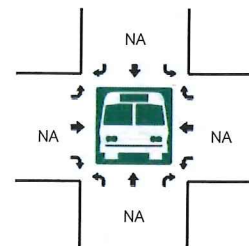
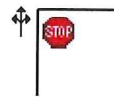
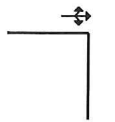
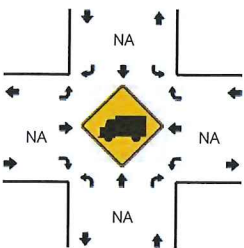
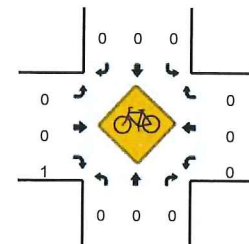
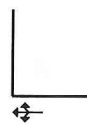
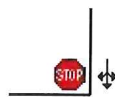
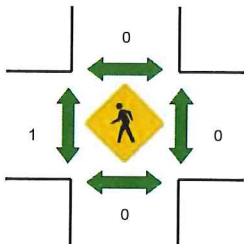
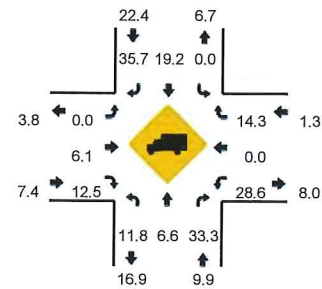
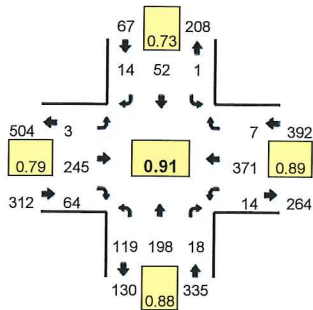

15-Min Count Period Beginning At	Pulehu Rd (Northbound)				Pulehu Rd (Southbound)				Hansen Rd (Eastbound)				Hansen Rd (Westbound)				Total	Hourly Totals
	Left	Thru	Right	U	Left	Thru	Right	U	Left	Thru	Right	U	Left	Thru	Right	U		
6:00 AM	9	13	1	0	0	8	0	0	0	25	7	0	7	52	1	0	123	
6:15 AM	15	19	3	0	0	6	1	0	0	24	21	0	2	76	0	0	167	
6:30 AM	16	32	4	0	0	13	0	0	1	35	14	0	5	72	0	0	192	
6:45 AM	17	29	2	0	0	8	2	0	1	43	6	0	6	76	0	0	190	672
7:00 AM	28	46	0	0	0	9	3	0	0	67	12	0	4	72	2	0	243	792
7:15 AM	27	48	6	0	1	18	4	0	1	75	23	0	3	95	2	0	303	928
7:30 AM	31	59	7	0	0	8	3	0	0	59	15	0	4	98	2	0	286	1022
7:45 AM	33	45	5	0	0	17	4	0	2	44	14	0	3	106	1	0	274	1106
8:00 AM	39	37	5	0	0	10	2	0	0	55	8	0	5	67	0	0	228	1091
8:15 AM	21	35	5	0	0	9	5	0	1	35	14	0	5	63	0	0	193	981
8:30 AM	23	28	2	0	0	9	6	0	2	57	17	0	6	68	2	0	220	915
8:45 AM	13	29	3	0	1	14	1	0	0	46	10	0	10	65	0	0	192	833
Peak 15-Min Flowrates	Northbound				Southbound				Eastbound				Westbound				Total	
	Left	Thru	Right	U	Left	Thru	Right	U	Left	Thru	Right	U	Left	Thru	Right	U		
All Vehicles	108	192	24	0	4	72	16	0	4	300	92	0	12	380	8	0	1212	
Heavy Trucks	20	8	8		0	16	8		0	12	12		4	0	0		88	
Pedestrians		0				0				4				0			4	
Bicycles	0	0	0		0	0	0		0	0	0		0	0	0		0	
Railroad																		
Stopped Buses																		

Comments:

Type of peak hour being reported: Intersection Peak

Method for determining peak hour: Total Entering Volume

LOCATION: Mokulele Hwy -- Hansen Rd
CITY/STATE: Kahului, HI

QC JOB #: 13803907
DATE: Tue, May 17 2016

Peak-Hour: 7:00 AM -- 8:00 AM
Peak 15-Min: 7:30 AM -- 7:45 AM

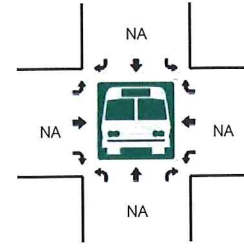
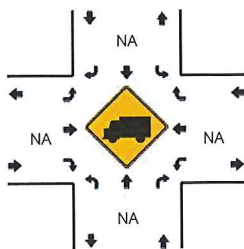
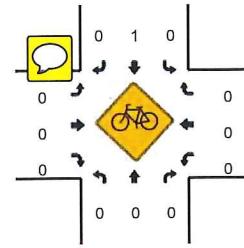
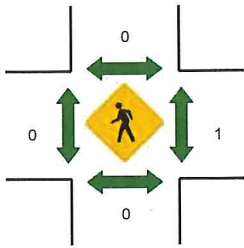
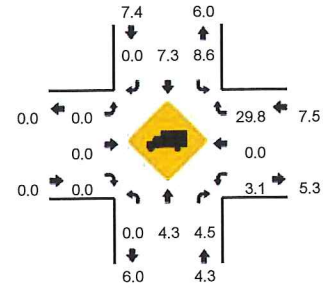
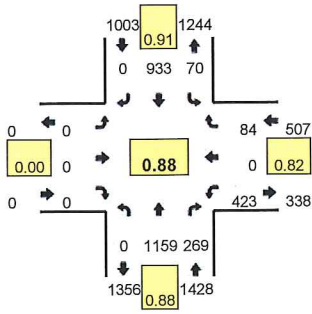

15-Min Count Period	Mokulele Hwy (Northbound)				Mokulele Hwy (Southbound)				Hansen Rd (Eastbound)				Hansen Rd (Westbound)				Total	Hourly Totals
	Left	Thru	Right	U	Left	Thru	Right	U	Left	Thru	Right	U	Left	Thru	Right	U		
Beginning At																		
6:00 AM	0	86	21	0	19	124	0	0	0	0	0	0	55	0	44	0	349	
6:15 AM	0	170	34	0	17	170	0	0	0	0	0	0	86	0	3	0	480	
6:30 AM	0	159	32	0	25	174	0	0	0	0	0	0	89	0	14	1	494	
6:45 AM	0	224	39	0	31	206	0	0	0	0	0	0	95	0	18	0	613	1936
7:00 AM	0	236	67	0	15	224	0	0	0	0	0	0	95	0	17	0	654	2241
7:15 AM	0	295	82	0	12	229	0	0	0	0	0	0	106	0	18	0	742	2503
7:30 AM	0	344	63	0	20	255	0	1	0	0	0	0	125	0	30	0	838	2847
7:45 AM	0	284	57	0	22	225	0	0	0	0	0	0	97	0	19	0	704	2938
8:00 AM	0	244	46	0	22	217	0	1	0	0	0	0	92	0	17	0	639	2923
8:15 AM	0	246	52	0	18	209	0	0	0	0	0	0	96	0	14	0	635	2816
8:30 AM	0	220	59	0	18	216	0	1	0	0	0	0	88	0	18	0	620	2598
8:45 AM	0	235	53	0	20	164	0	0	0	0	0	0	57	0	28	0	557	2451
Peak 15-Min Flowrates	Northbound				Southbound				Eastbound				Westbound				Total	
All Vehicles	0	1376	252	0	80	1020	0	4	0	0	0	0	500	0	120	0	3352	
Heavy Trucks	0	40	12		8	92	0		0	0	0		8	0	32		192	
Pedestrians	0				0				0				0				0	
Bicycles	0	0	0		0	0	0		0	0	0		0	0	0		0	
Railroad																		
Stopped Buses																		

Comments:

Type of peak hour being reported: Intersection Peak

Method for determining peak hour: Total Entering Volume

LOCATION: Pulehu Rd -- Vehicle Yard Dwy
 CITY/STATE: Kahului, HI

QC JOB #: 13803909
 DATE: Tue, May 17 2016

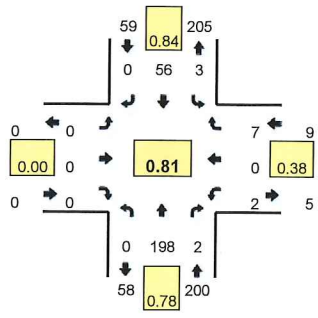

Peak-Hour: 7:00 AM -- 8:00 AM
 Peak 15-Min: 7:45 AM -- 8:00 AM

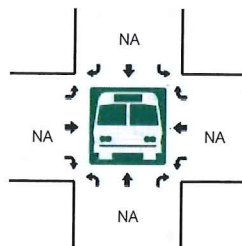
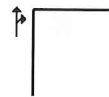
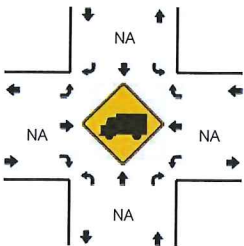
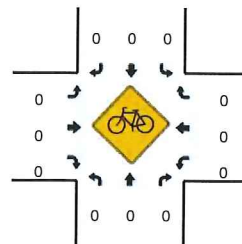
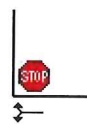
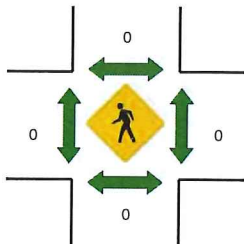
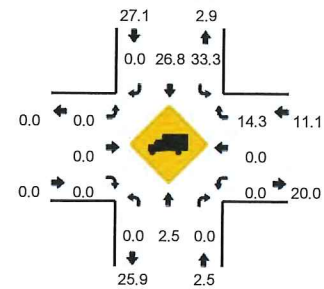

15-Min Count Period Beginning At	Pulehu Rd (Northbound)				Pulehu Rd (Southbound)				Vehicle Yard Dwy (Eastbound)				Vehicle Yard Dwy (Westbound)				Total	Hourly Totals
	Left	Thru	Right	U	Left	Thru	Right	U	Left	Thru	Right	U	Left	Thru	Right	U		
6:00 AM	0	21	0	0	2	9	0	0	0	0	0	0	0	0	1	0	33	
6:15 AM	0	18	0	0	3	10	0	0	0	0	0	0	0	0	0	0	31	
6:30 AM	0	28	0	0	1	7	0	0	0	0	0	0	0	0	0	0	36	
6:45 AM	0	48	0	0	0	15	0	0	0	0	0	0	0	0	1	0	64	164
7:00 AM	0	41	1	0	0	15	0	0	0	0	0	0	0	0	1	0	58	189
7:15 AM	0	42	0	0	1	15	0	0	0	0	0	0	1	0	5	0	64	222
7:30 AM	0	51	1	0	0	10	0	0	0	0	0	0	0	0	1	0	63	249
7:45 AM	0	64	0	0	2	16	0	0	0	0	0	0	1	0	0	0	83	268
8:00 AM	0	40	1	0	0	13	0	0	0	0	0	0	0	0	1	0	55	265
8:15 AM	0	33	0	0	1	19	0	0	0	0	0	0	0	0	2	0	55	256
8:30 AM	0	37	0	0	1	18	0	0	0	0	0	0	0	0	0	0	56	249
8:45 AM	0	33	0	0	1	21	0	0	0	0	0	0	0	0	2	0	57	223
Peak 15-Min Flowrates	Northbound				Southbound				Eastbound				Westbound				Total	
	Left	Thru	Right	U	Left	Thru	Right	U	Left	Thru	Right	U	Left	Thru	Right	U		
All Vehicles	0	256	0	0	8	64	0	0	0	0	0	0	4	0	0	0	332	
Heavy Trucks	0	0	0	0	4	24	0	0	0	0	0	0	0	0	0	0	28	
Pedestrians	0	0	0	0	0	0	0	0	0	0	0	0	0	0	0	0	0	
Bicycles	0	0	0	0	0	0	0	0	0	0	0	0	0	0	0	0	0	
Railroad	0	0	0	0	0	0	0	0	0	0	0	0	0	0	0	0	0	
Stopped Buses	0	0	0	0	0	0	0	0	0	0	0	0	0	0	0	0	0	

Comments:

Type of peak hour being reported: Intersection Peak

Method for determining peak hour: Total Entering Volume

LOCATION: Pulehu Rd -- Ho'okele St
CITY/STATE: Kahului, HI

QC JOB #: 13803904
DATE: Tue, May 17 2016

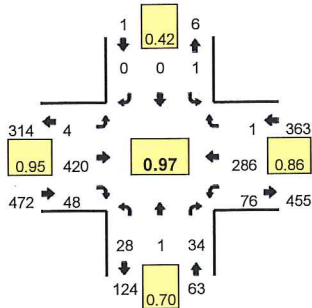

Peak-Hour: 4:15 PM -- 5:15 PM
Peak 15-Min: 4:30 PM -- 4:45 PM

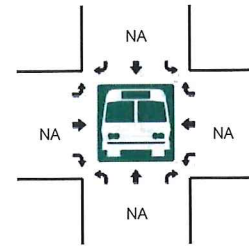
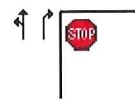
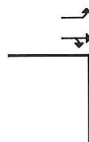
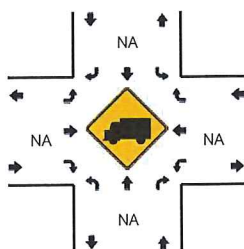
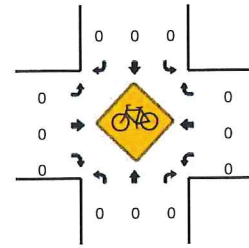
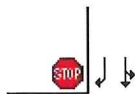
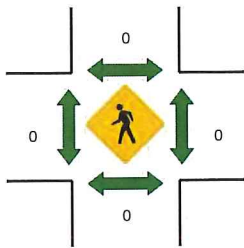
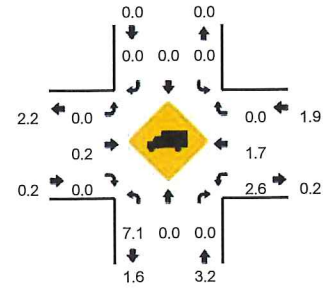

15-Min Count Period	Pulehu Rd (Northbound)				Pulehu Rd (Southbound)				Ho'okele St (Eastbound)				Ho'okele St (Westbound)				Total	Hourly Totals
	Left	Thru	Right	U	Left	Thru	Right	U	Left	Thru	Right	U	Left	Thru	Right	U		
3:00 PM	10	0	23	0	3	0	0	0	0	88	7	0	17	57	0	0	205	
3:15 PM	6	0	10	0	1	0	0	0	0	80	4	0	17	70	1	0	189	
3:30 PM	12	0	7	0	1	0	0	0	0	87	8	0	11	67	2	0	195	
3:45 PM	6	0	18	0	0	0	0	0	0	73	9	0	20	88	1	0	215	804
4:00 PM	6	0	11	0	1	0	0	0	0	90	8	0	12	66	0	0	194	793
4:15 PM	12	0	10	0	0	0	0	0	0	111	9	0	25	63	0	0	230	834
4:30 PM	5	0	7	0	0	0	0	0	0	111	8	0	19	82	0	0	232	871
4:45 PM	3	1	12	0	1	0	0	0	1	100	23	0	17	72	1	0	231	887
5:00 PM	8	0	5	0	0	0	0	0	3	98	8	0	15	69	0	0	206	899
5:15 PM	6	0	13	0	0	0	0	0	0	88	10	0	20	45	0	0	182	851
5:30 PM	3	0	4	0	0	0	0	0	0	66	10	0	10	67	1	0	161	780
5:45 PM	2	0	8	0	1	0	0	0	0	83	8	0	18	42	0	0	162	711
Peak 15-Min Flowrates	Northbound				Southbound				Eastbound				Westbound				Total	
All Vehicles	20	0	28	0	0	0	0	0	0	444	32	0	76	328	0	0	928	
Heavy Trucks	0	0	0		0	0	0		0	4	0		4	0	0		8	
Pedestrians	0	0	0		0	0	0		0	0	0		0	0	0		0	
Bicycles	0	0	0		0	0	0		0	0	0		0	0	0		0	
Railroad																		
Stopped Buses																		

Comments:

Type of peak hour being reported: Intersection Peak

Method for determining peak hour: Total Entering Volume

LOCATION: Ho'okele St -- Hana Hwy
CITY/STATE: Kahului, HI

QC JOB #: 13803902
DATE: Tue, May 17 2016

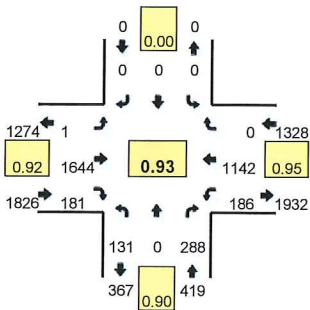

Peak-Hour: 3:45 PM -- 4:45 PM
Peak 15-Min: 4:30 PM -- 4:45 PM

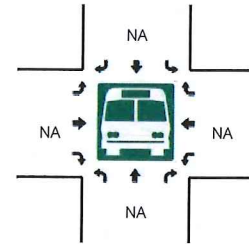
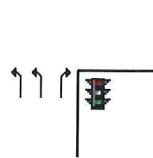
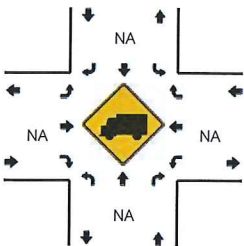
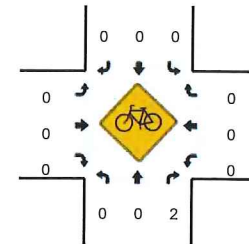
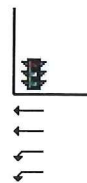
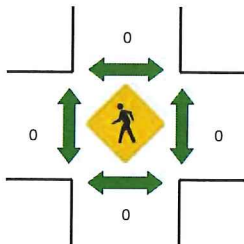
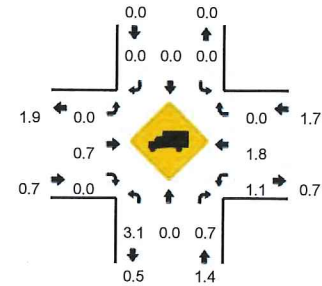

15-Min Count Period Beginning At	Ho'okele St (Northbound)				Ho'okele St (Southbound)				Hana Hwy (Eastbound)				Hana Hwy (Westbound)				Total	Hourly Totals
	Left	Thru	Right	U	Left	Thru	Right	U	Left	Thru	Right	U	Left	Thru	Right	U		
3:00 PM	55	0	58	0	0	0	0	0	0	293	36	0	38	292	0	0	772	
3:15 PM	43	0	47	0	0	0	0	0	0	306	49	0	41	318	0	0	804	
3:30 PM	36	0	53	0	0	0	0	0	0	334	42	0	44	314	0	0	823	
3:45 PM	32	0	55	0	0	0	0	0	0	395	45	1	57	318	0	0	903	3302
4:00 PM	33	0	65	0	0	0	0	0	0	405	43	0	42	296	0	0	884	3414
4:15 PM	29	0	83	0	0	0	0	0	0	394	41	0	34	248	0	0	829	3439
4:30 PM	37	0	85	0	0	0	0	0	0	450	52	0	53	280	0	0	957	3573
4:45 PM	36	0	70	0	0	0	0	0	0	455	41	0	45	234	0	0	881	3551
5:00 PM	20	0	80	0	0	0	0	0	0	488	49	1	37	214	0	0	889	3556
5:15 PM	38	0	61	0	0	0	0	0	0	403	27	0	31	238	0	0	798	3525
5:30 PM	19	0	46	0	0	0	0	0	0	404	43	0	38	230	0	0	780	3348
5:45 PM	26	0	62	0	0	0	0	0	0	328	26	0	28	202	0	0	672	3139

Peak 15-Min Flowrates	Northbound				Southbound				Eastbound				Westbound				Total
	Left	Thru	Right	U	Left	Thru	Right	U	Left	Thru	Right	U	Left	Thru	Right	U	
All Vehicles	148	0	340	0	0	0	0	0	0	1800	208	0	212	1120	0	0	3828
Heavy Trucks	4	0	0	0	0	0	0	0	0	4	0	0	0	16	0	0	24
Pedestrians																	0
Bicycles	0	0	2		0	0	0		0	0	0		0	0	0		2
Railroad																	
Stopped Buses																	

Comments:

LOCATION: Pulehu Rd -- Hansen Rd
CITY/STATE: Kahului, HI

QC JOB #: 13803906
DATE: Wed, May 18 2016

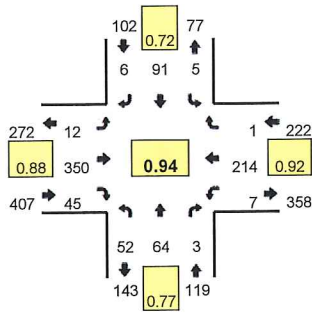

Peak-Hour: 3:30 PM -- 4:30 PM
Peak 15-Min: 3:30 PM -- 3:45 PM

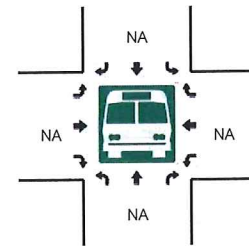
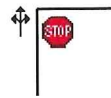
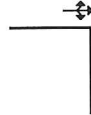
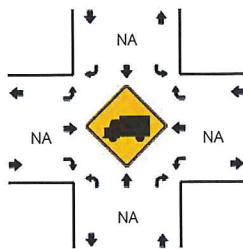
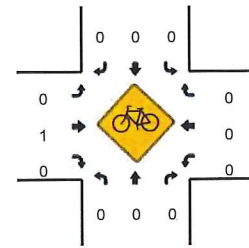
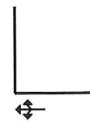
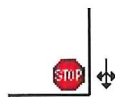
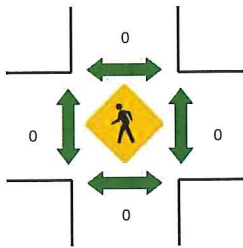
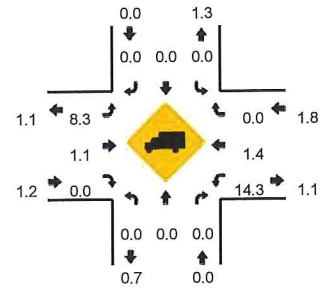

15-Min Count Period Beginning At	Pulehu Rd (Northbound)				Pulehu Rd (Southbound)				Hansen Rd (Eastbound)				Hansen Rd (Westbound)				Total	Hourly Totals
	Left	Thru	Right	U	Left	Thru	Right	U	Left	Thru	Right	U	Left	Thru	Right	U		
3:00 PM	11	16	2	0	1	6	2	0	3	74	7	0	1	62	1	0	186	
3:15 PM	16	24	3	0	2	16	2	0	0	73	7	0	1	49	0	0	193	
3:30 PM	15	16	1	0	3	18	3	0	5	94	7	0	5	59	1	0	227	
3:45 PM	12	16	1	0	2	24	0	0	1	81	13	0	2	57	0	0	209	815
4:00 PM	16	13	0	0	0	23	3	0	2	79	13	0	0	46	0	0	195	824
4:15 PM	9	19	1	0	0	26	0	0	4	96	12	0	0	52	0	0	219	850
4:30 PM	17	11	0	0	1	18	1	0	4	103	13	0	4	46	0	0	218	841
4:45 PM	13	15	1	0	1	19	3	0	0	75	13	1	1	39	1	0	182	814
5:00 PM	3	4	0	0	2	35	0	0	1	65	13	0	1	42	0	0	166	785
5:15 PM	8	15	2	0	1	20	4	0	1	88	13	0	2	44	0	0	198	764
5:30 PM	8	11	2	0	0	19	0	0	0	75	10	0	3	37	0	0	165	711
5:45 PM	6	5	0	0	0	17	0	0	4	68	6	0	1	32	1	0	140	669
Peak 15-Min Flowrates	Northbound				Southbound				Eastbound				Westbound				Total	
	Left	Thru	Right	U	Left	Thru	Right	U	Left	Thru	Right	U	Left	Thru	Right	U		
All Vehicles	60	64	4	0	12	72	12	0	20	376	28	0	20	236	4	0	908	
Heavy Trucks	0	0	0		0	0	0		0	8	0		4	8	0		20	
Pedestrians	0	0	0		0	0	0		0	0	0		0	0	0		0	
Bicycles	0	0	0		0	0	0		0	1	0		0	0	0		1	
Railroad																		
Stopped Buses																		

Comments:

Type of peak hour being reported: Intersection Peak

Method for determining peak hour: Total Entering Volume

LOCATION: Mokulele Hwy -- Hansen Rd
 CITY/STATE: Kahului, HI

QC JOB #: 13803908
 DATE: Tue, May 17 2016

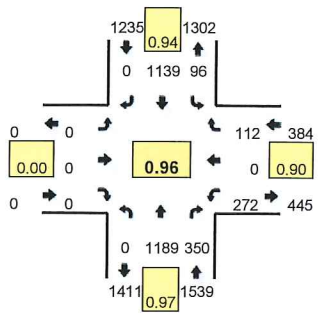

Peak-Hour: 3:30 PM -- 4:30 PM
 Peak 15-Min: 3:30 PM -- 3:45 PM

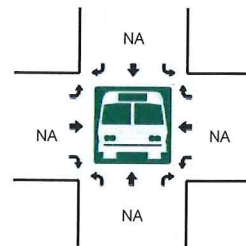
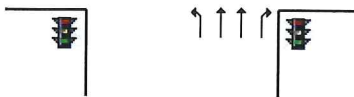
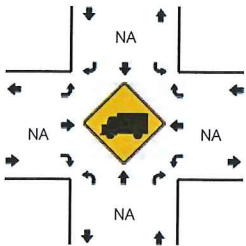
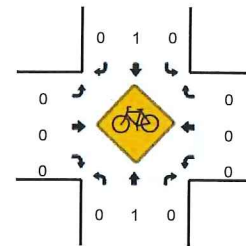
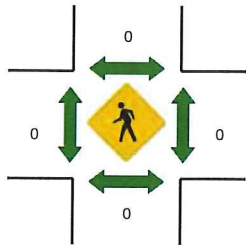
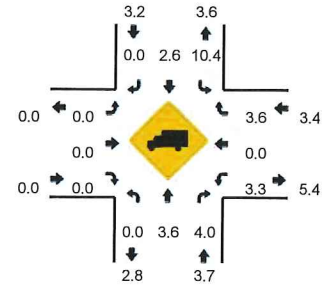

15-Min Count Period Beginning At	Mokulele Hwy (Northbound)				Mokulele Hwy (Southbound)				Hansen Rd (Eastbound)				Hansen Rd (Westbound)				Total	Hourly Totals
	Left	Thru	Right	U	Left	Thru	Right	U	Left	Thru	Right	U	Left	Thru	Right	U		
3:00 PM	0	239	70	0	20	238	0	1	0	0	0	0	72	0	36	0	676	
3:15 PM	0	300	81	0	19	266	0	1	0	0	0	0	66	0	11	0	744	
3:30 PM	0	326	76	0	19	298	0	0	0	0	0	0	59	0	46	0	824	
3:45 PM	0	282	114	0	33	274	0	1	0	0	0	0	74	0	26	0	804	3048
4:00 PM	0	313	68	0	15	289	0	0	0	0	0	0	62	0	27	0	774	3146
4:15 PM	0	268	92	0	28	278	0	0	0	0	0	0	77	0	13	0	756	3158
4:30 PM	0	306	87	0	34	299	0	0	0	0	0	0	56	0	27	0	809	3143
4:45 PM	0	246	85	0	20	269	0	0	0	0	0	0	55	0	16	0	691	3030
5:00 PM	0	217	98	0	20	289	0	1	0	0	0	0	37	0	17	0	679	2935
5:15 PM	0	225	89	0	39	236	0	0	0	0	0	0	47	0	14	0	650	2829
5:30 PM	0	238	88	0	24	249	0	0	0	0	0	0	51	0	7	0	657	2677
5:45 PM	0	201	70	0	20	234	0	0	0	0	0	0	44	0	12	0	581	2567

Peak 15-Min Flowrates	Northbound				Southbound				Eastbound				Westbound				Total
	Left	Thru	Right	U	Left	Thru	Right	U	Left	Thru	Right	U	Left	Thru	Right	U	
All Vehicles	0	1304	304	0	76	1192	0	0	0	0	0	0	236	0	184	0	3296
Heavy Trucks	0	40	8	0	16	40	0	0	0	0	0	0	12	0	12	0	128
Pedestrians	0	0	0	0	0	0	0	0	0	0	0	0	0	0	0	0	0
Bicycles	0	0	0	0	0	0	0	0	0	0	0	0	0	0	0	0	0
Railroad	0	0	0	0	0	0	0	0	0	0	0	0	0	0	0	0	0
Stopped Buses	0	0	0	0	0	0	0	0	0	0	0	0	0	0	0	0	0

Comments:

Type of peak hour being reported: Intersection Peak

Method for determining peak hour: Total Entering Volume

LOCATION: Pulehu Rd -- Vehicle Yard Dwy
CITY/STATE: Kahului, HI

QC JOB #: 13803910
DATE: Wed, May 18 2016

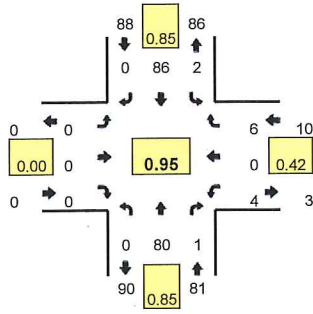

Peak-Hour: 3:15 PM -- 4:15 PM
Peak 15-Min: 3:30 PM -- 3:45 PM

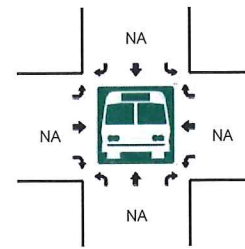
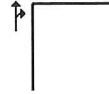
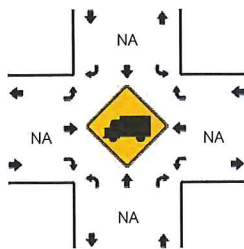
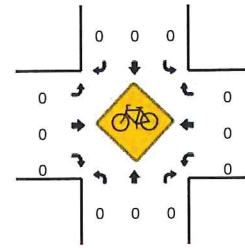
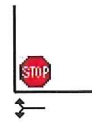
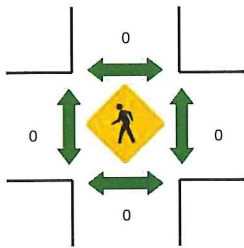
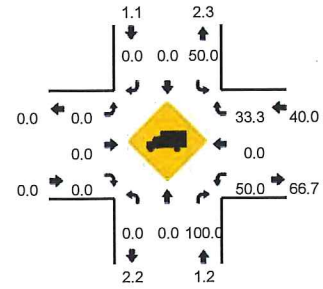

15-Min Count Period	Pulehu Rd (Northbound)				Pulehu Rd (Southbound)				Vehicle Yard Dwy (Eastbound)				Vehicle Yard Dwy (Westbound)				Total	Hourly Totals	
	Beginning At	Left	Thru	Right	U	Left	Thru	Right	U	Left	Thru	Right	U	Left	Thru	Right			U
3:00 PM	0	23	0	0	0	16	0	0	0	0	0	0	0	0	0	0	0	39	
3:15 PM	0	19	1	0	0	1	17	0	0	0	0	0	0	1	0	5	0	44	
3:30 PM	0	25	0	0	0	1	19	0	0	0	0	0	0	2	0	0	0	47	
3:45 PM	0	17	0	0	0	0	26	0	0	0	0	0	0	1	0	0	0	44	174
4:00 PM	0	19	0	0	0	0	24	0	0	0	0	0	0	0	0	1	0	44	179
4:15 PM	0	10	0	0	0	1	29	0	0	0	0	0	0	0	0	0	0	40	175
4:30 PM	0	25	1	0	0	0	23	0	0	0	0	0	0	2	0	0	0	51	179
4:45 PM	0	15	1	0	0	0	21	0	0	0	0	0	0	0	0	0	0	37	172
5:00 PM	0	7	0	0	0	1	30	0	0	0	0	0	0	0	0	2	0	40	168
5:15 PM	0	12	0	0	0	0	31	0	0	0	0	0	0	0	0	0	0	43	171
5:30 PM	0	15	0	0	0	1	20	0	0	0	0	0	0	0	0	0	0	36	156
5:45 PM	0	7	0	0	0	0	21	0	0	0	0	0	0	0	0	0	0	28	147
Peak 15-Min Flowrates		Northbound				Southbound				Eastbound				Westbound				Total	
All Vehicles	0	100	0	0	0	4	76	0	0	0	0	0	0	8	0	0	0	188	
Heavy Trucks	0	0	0	0	0	4	0	0	0	0	0	0	0	4	0	0	0	8	
Pedestrians		0				0								0				0	
Bicycles	0	0	0			0	0	0			0	0	0	0	0	0		0	
Railroad																			
Stopped Buses																			

Comments:

LOCATION: Pulehu Rd S of Hansen Rd SPECIFIC LOCATION: Pulehu Rd S of Hansen Rd CITY/STATE: Kula, HI															QC JOB #: 13803911 DIRECTION: NB DATE: May 17 2016	
Start Time	Motor-cycles	Cars & Trailer	2 Axle Long	Buses	2 Axle 6 Tire	3 Axle Single	4 Axle Single	<5 Axle Double	5 Axle Double	>6 Axle Double	<6 Axle Multi	6 Axle Multi	>6 Axle Multi	Not Classified	Total	
12:00 AM	0	1	0	0	0	0	0	0	0	0	0	0	0	0	1	
1:00 AM	0	1	0	0	0	0	0	0	0	0	0	0	0	0	1	
2:00 AM	0	1	0	0	0	0	0	0	0	0	0	0	0	0	1	
3:00 AM	0	2	0	0	0	0	0	0	0	0	0	0	0	0	2	
4:00 AM	0	3	2	0	1	0	0	0	0	0	0	0	0	0	6	
5:00 AM	0	15	18	0	2	0	0	0	0	0	0	0	0	0	35	
6:00 AM	2	63	81	0	15	5	0	0	0	0	0	0	0	1	167	
7:00 AM	5	98	87	1	28	5	0	2	0	0	0	0	0	65	291	
8:00 AM	1	115	74	1	26	10	0	4	2	0	0	0	0	9	242	
9:00 AM	1	60	69	1	33	9	0	2	3	0	0	0	0	5	183	
10:00 AM	1	54	69	5	31	7	0	3	2	0	0	0	0	10	182	
11:00 AM	0	42	83	0	32	4	0	3	1	0	0	0	0	4	169	
12:00 PM	0	49	91	4	23	9	0	0	0	0	0	0	0	7	183	
1:00 PM	1	53	62	1	27	5	0	4	0	0	0	0	0	4	157	
2:00 PM	1	60	81	2	18	4	0	2	1	0	0	0	0	4	173	
3:00 PM	0	67	52	2	11	1	0	1	0	0	0	0	0	0	134	
4:00 PM	0	57	45	0	16	0	0	1	0	0	0	0	0	2	121	
5:00 PM	2	51	26	0	6	0	0	2	0	0	0	0	0	1	88	
6:00 PM	0	32	19	0	5	0	0	0	0	0	0	0	0	2	58	
7:00 PM	0	21	15	0	3	0	0	1	0	0	0	0	0	1	41	
8:00 PM	0	12	7	0	1	0	0	0	0	0	0	0	0	0	20	
9:00 PM	0	4	3	0	1	0	0	0	0	0	0	0	0	0	8	
10:00 PM	0	2	2	0	0	0	0	0	0	0	0	0	0	0	4	
11:00 PM	0	2	1	0	1	0	0	0	0	0	0	0	0	0	4	
Day Total	14	865	887	17	280	59	0	25	9	0	0	0	0	115	2271	
Percent	0.6%	38.1%	39.1%	0.7%	12.3%	2.6%	0.0%	1.1%	0.4%	0.0%	0.0%	0.0%	0.0%	5.1%		
ADT 2271																
AM Peak Volume	7:00 AM	8:00 AM	7:00 AM	10:00 AM	9:00 AM	8:00 AM		8:00 AM	9:00 AM					7:00 AM	7:00 AM	
	5	115	87	5	33	10		4	3					65	291	
PM Peak Volume	5:00 PM	3:00 PM	12:00 PM	12:00 PM	1:00 PM	12:00 PM		1:00 PM	2:00 PM					12:00 PM	12:00 PM	
	2	67	91	4	27	9		4	1					7	183	
<i>Comments:</i>																

LOCATION: Pulehu Rd S of Hansen Rd SPECIFIC LOCATION: Pulehu Rd S of Hansen Rd CITY/STATE: Kula, HI														QC JOB #: 13803911 DIRECTION: NB DATE: May 18 2016	
Start Time	Motor-cycles	Cars & Trailer	2 Axle Long	Buses	2 Axle 6 Tire	3 Axle Single	4 Axle Single	<5 Axle Double	5 Axle Double	>6 Axle Double	<6 Axle Multi	6 Axle Multi	>6 Axle Multi	Not Classified	Total
12:00 AM	0	2	0	0	0	0	0	0	0	0	0	0	0	0	2
1:00 AM	0	1	0	0	0	0	0	0	0	0	0	0	0	0	1
2:00 AM	0	1	1	0	0	0	0	0	0	0	0	0	0	0	2
3:00 AM	0	2	0	0	0	0	0	0	0	0	0	0	0	0	2
4:00 AM	0	2	2	0	0	0	0	0	0	0	0	0	0	0	4
5:00 AM	0	21	17	0	2	0	0	1	0	0	0	0	0	0	41
6:00 AM	3	61	65	2	13	2	0	1	1	0	0	0	0	1	149
7:00 AM	5	125	76	1	19	5	0	4	0	0	0	0	0	70	305
8:00 AM	1	101	71	2	23	3	0	2	1	0	0	0	0	9	213
9:00 AM	1	73	70	3	31	5	0	3	1	0	0	0	0	4	191
10:00 AM	2	62	91	5	25	2	0	2	1	0	0	0	0	7	197
11:00 AM	0	53	68	2	35	2	0	5	1	0	0	0	0	4	170
12:00 PM	0	62	62	2	21	5	0	4	1	0	0	0	0	9	166
1:00 PM	0	54	71	1	25	2	0	0	1	0	0	0	0	12	166
2:00 PM	0	61	66	1	23	3	0	3	1	0	0	0	0	9	167
3:00 PM	0	73	41	0	13	4	0	1	0	0	0	0	0	3	135
4:00 PM	0	57	42	0	16	0	0	1	0	0	0	0	0	3	119
5:00 PM	0	42	19	0	4	0	0	1	0	0	0	0	0	2	68
6:00 PM	0	25	7	0	7	0	0	1	0	0	0	0	0	0	40
7:00 PM	0	13	6	0	5	0	0	0	0	0	0	0	0	0	24
8:00 PM	0	16	6	0	0	0	0	0	0	0	0	0	0	0	22
9:00 PM	0	9	2	0	0	0	0	0	0	0	0	0	0	0	11
10:00 PM	0	3	4	0	0	0	0	0	0	0	0	0	0	0	7
11:00 PM	0	2	1	0	0	0	0	0	0	0	0	0	0	1	4
Day Total	12	921	788	19	262	33	0	29	8	0	0	0	0	134	2206
Percent	0.5%	41.7%	35.7%	0.9%	11.9%	1.5%	0.0%	1.3%	0.4%	0.0%	0.0%	0.0%	0.0%	6.1%	
ADT 2206															
AM Peak Volume	7:00 AM 5	7:00 AM 125	10:00 AM 91	10:00 AM 5	11:00 AM 35	7:00 AM 5		11:00 AM 5	6:00 AM 1					7:00 AM 70	7:00 AM 305
PM Peak Volume		3:00 PM 73	1:00 PM 71	12:00 PM 2	1:00 PM 25	12:00 PM 5		12:00 PM 4	12:00 PM 1					1:00 PM 12	2:00 PM 167
<i>Comments:</i>															

LOCATION: Pulehu Rd S of Hansen Rd													QC JOB #: 13803911		
SPECIFIC LOCATION: Pulehu Rd S of Hansen Rd													DIRECTION: NB		
CITY/STATE: Kula, HI													DATE: May 17 2016 - May 18 2016		
Start Time	Motor-cycles	Cars & Trailer	2 Axle Long	Buses	2 Axle 6 Tire	3 Axle Single	4 Axle Single	<5 Axle Double	5 Axle Double	>6 Axle Double	<6 Axle Multi	6 Axle Multi	>6 Axle Multi	Not Classified	Total
Grand Total	26	1786	1675	36	542	92	0	54	17	0	0	0	0	249	4477
Percent	0.6%	39.9%	37.4%	0.8%	12.1%	2.1%	0.0%	1.2%	0.4%	0.0%	0.0%	0.0%	0.0%	5.6%	
ADT 2238															
<i>Comments:</i>															



Type of report: Tube Count - Volume Data

LOCATION: Pulehu Rd S of Hansen Rd SPECIFIC LOCATION: Pulehu Rd S of Hansen Rd CITY/STATE: Kula, HI							QC JOB #: 13803911 DIRECTION: NB DATE: May 17 2016 - May 18 2016			
Start Time	Mon 17-May-16	Tue 18-May-16	Wed 18-May-16	Thu	Fri	Average Weekday Hourly Traffic	Sat	Sun	Average Week Hourly Traffic	Average Week Profile
12:00 AM		1	2			2			2	
1:00 AM		1	1			1			1	
2:00 AM		1	2			2			2	
3:00 AM		2	2			2			2	
4:00 AM		6	4			5			5	
5:00 AM		35	41			38			38	
6:00 AM		167	149			158			158	
7:00 AM		291	305			298			298	
8:00 AM		242	213			228			228	
9:00 AM		183	191			187			187	
10:00 AM		182	197			190			190	
11:00 AM		169	170			170			170	
12:00 PM		183	166			175			175	
1:00 PM		157	166			162			162	
2:00 PM		173	167			170			170	
3:00 PM		134	135			135			135	
4:00 PM		121	119			120			120	
5:00 PM		88	68			78			78	
6:00 PM		58	40			49			49	
7:00 PM		41	24			33			33	
8:00 PM		20	22			21			21	
9:00 PM		8	11			10			10	
10:00 PM		4	7			6			6	
11:00 PM		4	4			4			4	
Day Total		2271	2206			2244			2244	
% Weekday Average		101.2%	98.3%							
% Week Average		101.2%	98.3%			100.0%				
AM Peak Volume		7:00 AM 291	7:00 AM 305			7:00 AM 298			7:00 AM 298	
PM Peak Volume		12:00 PM 183	2:00 PM 167			12:00 PM 175			12:00 PM 175	
<i>Comments:</i>										

LOCATION: Pulehu Rd S of Hansen Rd SPECIFIC LOCATION: Pulehu Rd S of Hansen Rd CITY/STATE: Kula, HI															QC JOB #: 13803911 DIRECTION: SB DATE: May 17 2016	
Start Time	Motor-cycles	Cars & Trailer	2 Axle Long	Buses	2 Axle 6 Tire	3 Axle Single	4 Axle Single	<5 Axle Double	5 Axle Double	>6 Axle Double	<6 Axle Multi	6 Axle Multi	>6 Axle Multi	Not Classified	Total	
12:00 AM	0	3	0	0	0	0	0	0	0	0	0	0	0	0	3	
1:00 AM	0	2	0	0	0	0	0	0	0	0	0	0	0	0	2	
2:00 AM	0	1	1	0	0	0	0	0	0	0	0	0	0	0	2	
3:00 AM	0	0	3	0	0	0	0	0	0	0	0	0	0	1	4	
4:00 AM	0	2	6	0	1	0	0	0	0	0	0	0	0	0	9	
5:00 AM	0	8	20	1	3	0	0	0	0	0	0	0	0	0	32	
6:00 AM	0	26	47	4	20	5	0	3	0	0	0	0	0	3	108	
7:00 AM	2	18	40	1	20	6	0	1	0	0	0	0	0	37	125	
8:00 AM	0	33	56	4	31	7	0	2	2	0	0	0	0	11	146	
9:00 AM	0	28	51	4	31	9	0	1	1	0	0	0	0	4	129	
10:00 AM	0	40	75	5	20	7	0	2	0	0	0	0	0	11	160	
11:00 AM	0	34	74	4	33	2	0	0	1	0	0	0	0	4	152	
12:00 PM	0	38	70	1	32	8	0	2	1	0	0	0	0	7	159	
1:00 PM	0	48	52	3	25	7	0	3	0	0	0	0	0	10	148	
2:00 PM	0	56	75	1	29	2	0	2	0	0	0	0	0	6	171	
3:00 PM	2	63	55	1	21	0	0	1	0	0	0	0	0	1	144	
4:00 PM	0	76	48	0	28	0	0	0	1	0	0	0	0	0	153	
5:00 PM	1	74	49	0	14	0	0	0	0	0	0	0	0	3	141	
6:00 PM	0	66	31	0	10	0	0	1	0	0	0	0	0	4	112	
7:00 PM	0	41	21	0	12	0	0	0	0	0	0	0	0	1	75	
8:00 PM	0	24	14	0	3	0	0	0	0	0	0	0	0	0	41	
9:00 PM	0	11	12	0	0	0	0	0	0	0	0	0	0	1	24	
10:00 PM	0	12	8	0	2	0	0	0	0	0	0	0	0	0	22	
11:00 PM	0	5	6	0	0	0	0	0	0	0	0	0	0	0	11	
Day Total	5	709	814	29	335	53	0	18	6	0	0	0	0	104	2073	
Percent	0.2%	34.2%	39.3%	1.4%	16.2%	2.6%	0.0%	0.9%	0.3%	0.0%	0.0%	0.0%	0.0%	5.0%		
ADT 2073																
AM Peak Volume	7:00 AM	10:00 AM	10:00 AM	10:00 AM	11:00 AM	9:00 AM		6:00 AM	8:00 AM					7:00 AM	10:00 AM	
	2	40	75	5	33	9		3	2					37	160	
PM Peak Volume	3:00 PM	4:00 PM	2:00 PM	1:00 PM	12:00 PM	12:00 PM		1:00 PM	12:00 PM					1:00 PM	2:00 PM	
	2	76	75	3	32	8		3	1					10	171	
Comments:																

LOCATION: Pulehu Rd S of Hansen Rd SPECIFIC LOCATION: Pulehu Rd S of Hansen Rd CITY/STATE: Kula, HI															QC JOB #: 13803911 DIRECTION: SB DATE: May 18 2016	
Start Time	Motor-cycles	Cars & Trailer	2 Axle Long	Buses	2 Axle 6 Tire	3 Axle Single	4 Axle Single	<5 Axle Double	5 Axle Double	>6 Axle Double	<6 Axle Multi	6 Axle Multi	>6 Axle Multi	Not Classified	Total	
12:00 AM	0	2	4	0	0	0	0	0	0	0	0	0	0	0	6	
1:00 AM	0	1	1	0	1	0	0	0	0	0	0	0	0	0	3	
2:00 AM	0	1	0	0	0	0	0	0	0	0	0	0	0	0	1	
3:00 AM	0	0	2	0	1	0	0	0	0	0	0	0	0	0	3	
4:00 AM	0	3	1	0	1	0	0	0	0	0	0	0	0	0	5	
5:00 AM	0	12	16	0	9	0	0	0	0	0	0	0	0	0	37	
6:00 AM	1	26	42	5	17	4	0	3	1	0	0	0	0	0	99	
7:00 AM	0	24	31	3	20	0	0	0	0	0	0	0	0	41	119	
8:00 AM	1	34	45	3	27	2	1	4	1	0	0	0	0	10	128	
9:00 AM	0	30	64	5	31	2	0	2	1	0	0	0	0	2	137	
10:00 AM	0	43	71	2	33	2	0	3	2	0	0	0	0	8	164	
11:00 AM	1	40	69	2	34	6	0	2	2	0	0	0	0	4	160	
12:00 PM	0	40	60	3	21	3	0	5	1	0	0	0	0	21	154	
1:00 PM	2	41	58	4	30	2	0	0	0	0	0	0	0	19	156	
2:00 PM	1	51	52	0	30	4	0	3	0	0	0	0	0	7	148	
3:00 PM	0	49	37	0	12	0	0	2	0	0	0	0	0	1	101	
4:00 PM	0	60	63	0	26	0	0	1	0	0	0	0	0	3	153	
5:00 PM	0	65	65	0	13	0	0	1	0	0	0	0	0	5	149	
6:00 PM	0	26	42	0	13	0	0	0	0	0	0	0	0	0	81	
7:00 PM	1	28	29	0	9	0	0	0	0	0	0	0	0	0	67	
8:00 PM	0	17	25	0	4	0	0	0	0	0	0	0	0	0	46	
9:00 PM	0	13	11	0	5	0	0	0	0	0	0	0	0	0	29	
10:00 PM	0	13	11	0	2	0	0	0	0	0	0	0	0	0	26	
11:00 PM	0	7	5	0	0	0	0	0	0	0	0	0	0	0	12	
Day Total	7	626	804	27	339	25	1	26	8	0	0	0	0	121	1984	
Percent	0.4%	31.6%	40.5%	1.4%	17.1%	1.3%	0.1%	1.3%	0.4%	0.0%	0.0%	0.0%	0.0%	6.1%		
ADT 1984																
AM Peak Volume	6:00 AM	10:00 AM	10:00 AM	6:00 AM	11:00 AM	11:00 AM	8:00 AM	8:00 AM	10:00 AM						7:00 AM	10:00 AM
	1	43	71	5	34	6	1	4	2						41	164
PM Peak Volume	1:00 PM	5:00 PM	5:00 PM	1:00 PM	1:00 PM	2:00 PM	12:00 PM		12:00 PM						12:00 PM	1:00 PM
	2	65	65	4	30	4	5		1						21	156
<i>Comments:</i>																

LOCATION: Pulehu Rd S of Hansen Rd														QC JOB #: 13803911	
SPECIFIC LOCATION: Pulehu Rd S of Hansen Rd														DIRECTION: SB	
CITY/STATE: Kula, HI														DATE: May 17 2016 - May 18 2016	
Start Time	Motor-cycles	Cars & Trailer	2 Axle Long	Buses	2 Axle 6 Tire	3 Axle Single	4 Axle Single	<5 Axle Double	5 Axle Double	>6 Axle Double	<6 Axle Multi	6 Axle Multi	>6 Axle Multi	Not Classified	Total
Grand Total	12	1335	1618	56	674	78	1	44	14	0	0	0	0	225	4057
Percent	0.3%	32.9%	39.9%	1.4%	16.6%	1.9%	0.0%	1.1%	0.3%	0.0%	0.0%	0.0%	0.0%	5.5%	
ADT 2028															
<i>Comments:</i>															



Type of report: Tube Count - Volume Data

LOCATION: Pulehu Rd S of Hansen Rd SPECIFIC LOCATION: Pulehu Rd S of Hansen Rd CITY/STATE: Kula, HI						QC JOB #: 13803911 DIRECTION: SB DATE: May 17 2016 - May 18 2016				
Start Time	Mon 17-May-16	Tue 18-May-16	Wed 18-May-16	Thu	Fri	Average Weekday Hourly Traffic	Sat	Sun	Average Week Hourly Traffic	Average Week Profile
12:00 AM		3	6			5			5	
1:00 AM		2	3			3			3	
2:00 AM		2	1			2			2	
3:00 AM		4	3			4			4	
4:00 AM		9	5			7			7	
5:00 AM		32	37			35			35	
6:00 AM		108	99			104			104	
7:00 AM		125	119			122			122	
8:00 AM		146	128			137			137	
9:00 AM		129	137			133			133	
10:00 AM		160	164			162			162	
11:00 AM		152	160			156			156	
12:00 PM		159	154			157			157	
1:00 PM		148	156			152			152	
2:00 PM		171	148			160			160	
3:00 PM		144	101			123			123	
4:00 PM		153	153			153			153	
5:00 PM		141	149			145			145	
6:00 PM		112	81			97			97	
7:00 PM		75	67			71			71	
8:00 PM		41	46			44			44	
9:00 PM		24	29			27			27	
10:00 PM		22	26			24			24	
11:00 PM		11	12			12			12	
Day Total		2073	1984			2035			2035	
% Weekday Average		101.9%	97.5%							
% Week Average		101.9%	97.5%			100.0%				
AM Peak Volume		10:00 AM 160	10:00 AM 164			10:00 AM 162			10:00 AM 162	
PM Peak Volume		2:00 PM 171	1:00 PM 156			2:00 PM 160			2:00 PM 160	
<i>Comments:</i>										

LOCATION: Pulehu Rd S of Hansen Rd SPECIFIC LOCATION: Pulehu Rd S of Hansen Rd CITY/STATE: Kula, HI															QC JOB #: 13803911 DIRECTION: NB/SB DATE: May 17 2016	
Start Time	Motor-cycles	Cars & Trailer	2 Axle Long	Buses	2 Axle 6 Tire	3 Axle Single	4 Axle Single	<5 Axle Double	5 Axle Double	>6 Axle Double	<6 Axle Multi	6 Axle Multi	>6 Axle Multi	Not Classified	Total	
12:00 AM	0	4	0	0	0	0	0	0	0	0	0	0	0	0	4	
1:00 AM	0	3	0	0	0	0	0	0	0	0	0	0	0	0	3	
2:00 AM	0	2	1	0	0	0	0	0	0	0	0	0	0	0	3	
3:00 AM	0	2	3	0	0	0	0	0	0	0	0	0	0	1	6	
4:00 AM	0	5	8	0	2	0	0	0	0	0	0	0	0	0	15	
5:00 AM	0	23	38	1	5	0	0	0	0	0	0	0	0	0	67	
6:00 AM	2	89	128	4	35	10	0	3	0	0	0	0	0	4	275	
7:00 AM	7	116	127	2	48	11	0	3	0	0	0	0	0	102	416	
8:00 AM	1	148	130	5	57	17	0	6	4	0	0	0	0	20	388	
9:00 AM	1	88	120	5	64	18	0	3	4	0	0	0	0	9	312	
10:00 AM	1	94	144	10	51	14	0	5	2	0	0	0	0	21	342	
11:00 AM	0	76	157	4	65	6	0	3	2	0	0	0	0	8	321	
12:00 PM	0	87	161	5	55	17	0	2	1	0	0	0	0	14	342	
1:00 PM	1	101	114	4	52	12	0	7	0	0	0	0	0	14	305	
2:00 PM	1	116	156	3	47	6	0	4	1	0	0	0	0	10	344	
3:00 PM	2	130	107	3	32	1	0	2	0	0	0	0	0	1	278	
4:00 PM	0	133	93	0	44	0	0	1	1	0	0	0	0	2	274	
5:00 PM	3	125	75	0	20	0	0	2	0	0	0	0	0	4	229	
6:00 PM	0	98	50	0	15	0	0	1	0	0	0	0	0	6	170	
7:00 PM	0	62	36	0	15	0	0	1	0	0	0	0	0	2	116	
8:00 PM	0	36	21	0	4	0	0	0	0	0	0	0	0	0	61	
9:00 PM	0	15	15	0	1	0	0	0	0	0	0	0	0	1	32	
10:00 PM	0	14	10	0	2	0	0	0	0	0	0	0	0	0	26	
11:00 PM	0	7	7	0	1	0	0	0	0	0	0	0	0	0	15	
Day Total	19	1574	1701	46	615	112	0	43	15	0	0	0	0	219	4344	
Percent	0.4%	36.2%	39.2%	1.1%	14.2%	2.6%	0.0%	1.0%	0.3%	0.0%	0.0%	0.0%	0.0%	5.0%		
ADT 4344																
AM Peak Volume	7:00 AM	8:00 AM	11:00 AM	10:00 AM	11:00 AM	9:00 AM	8:00 AM		8:00 AM						7:00 AM	7:00 AM
	7	148	157	10	65	18	6		4						102	416
PM Peak Volume	5:00 PM	4:00 PM	12:00 PM	12:00 PM	12:00 PM	12:00 PM	1:00 PM		12:00 PM						12:00 PM	2:00 PM
	3	133	161	5	55	17	7		1						14	344
Comments:																

LOCATION: Pulehu Rd S of Hansen Rd SPECIFIC LOCATION: Pulehu Rd S of Hansen Rd CITY/STATE: Kula, HI															QC JOB #: 13803911 DIRECTION: NB/SB DATE: May 18 2016	
Start Time	Motor-cycles	Cars & Trailer	2 Axle Long	Buses	2 Axle 6 Tire	3 Axle Single	4 Axle Single	<5 Axle Double	5 Axle Double	>6 Axle Double	<6 Axle Multi	6 Axle Multi	>6 Axle Multi	Not Classified	Total	
12:00 AM	0	4	4	0	0	0	0	0	0	0	0	0	0	0	8	
1:00 AM	0	2	1	0	1	0	0	0	0	0	0	0	0	0	4	
2:00 AM	0	2	1	0	0	0	0	0	0	0	0	0	0	0	3	
3:00 AM	0	2	2	0	1	0	0	0	0	0	0	0	0	0	5	
4:00 AM	0	5	3	0	1	0	0	0	0	0	0	0	0	0	9	
5:00 AM	0	33	33	0	11	0	0	1	0	0	0	0	0	0	78	
6:00 AM	4	87	107	7	30	6	0	4	2	0	0	0	0	0	248	
7:00 AM	5	149	107	4	39	5	0	4	0	0	0	0	0	111	424	
8:00 AM	2	135	116	5	50	5	1	6	2	0	0	0	0	19	341	
9:00 AM	1	103	134	8	62	7	0	5	2	0	0	0	0	6	328	
10:00 AM	2	105	162	7	58	4	0	5	3	0	0	0	0	15	361	
11:00 AM	1	93	137	4	69	8	0	7	3	0	0	0	0	8	330	
12:00 PM	0	102	122	5	42	8	0	9	2	0	0	0	0	30	320	
1:00 PM	2	95	129	5	55	4	0	0	1	0	0	0	0	31	322	
2:00 PM	1	112	118	1	53	7	0	6	1	0	0	0	0	16	315	
3:00 PM	0	122	78	0	25	4	0	3	0	0	0	0	0	4	236	
4:00 PM	0	117	105	0	42	0	0	2	0	0	0	0	0	6	272	
5:00 PM	0	107	84	0	17	0	0	2	0	0	0	0	0	7	217	
6:00 PM	0	51	49	0	20	0	0	1	0	0	0	0	0	0	121	
7:00 PM	1	41	35	0	14	0	0	0	0	0	0	0	0	0	91	
8:00 PM	0	33	31	0	4	0	0	0	0	0	0	0	0	0	68	
9:00 PM	0	22	13	0	5	0	0	0	0	0	0	0	0	0	40	
10:00 PM	0	16	15	0	2	0	0	0	0	0	0	0	0	0	33	
11:00 PM	0	9	6	0	0	0	0	0	0	0	0	0	0	1	16	
Day Total	19	1547	1592	46	601	58	1	55	16	0	0	0	0	255	4190	
Percent	0.5%	36.9%	38.0%	1.1%	14.3%	1.4%	0.0%	1.3%	0.4%	0.0%	0.0%	0.0%	0.0%	6.1%		
ADT 4190																
AM Peak Volume	7:00 AM	7:00 AM	10:00 AM	9:00 AM	11:00 AM	11:00 AM	8:00 AM	11:00 AM	10:00 AM						7:00 AM	7:00 AM
	5	149	162	8	69	8	1	7	3						111	424
PM Peak Volume	1:00 PM	3:00 PM	1:00 PM	12:00 PM	1:00 PM	12:00 PM	12:00 PM		12:00 PM						1:00 PM	1:00 PM
	2	122	129	5	55	8	9		2						31	322
<i>Comments:</i>																

LOCATION: Pulehu Rd S of Hansen Rd														QC JOB #: 13803911	
SPECIFIC LOCATION: Pulehu Rd S of Hansen Rd														DIRECTION: NB/SB	
CITY/STATE: Kula, HI														DATE: May 17 2016 - May 18 2016	
Start Time	Motor-cycles	Cars & Trailer	2 Axle Long	Buses	2 Axle 6 Tire	3 Axle Single	4 Axle Single	<5 Axle Double	5 Axle Double	>6 Axle Double	<6 Axle Multi	6 Axle Multi	>6 Axle Multi	Not Classified	Total
Grand Total	38	3121	3293	92	1216	170	1	98	31	0	0	0	0	474	8534
Percent	0.4%	36.6%	38.6%	1.1%	14.2%	2.0%	0.0%	1.1%	0.4%	0.0%	0.0%	0.0%	0.0%	5.6%	
ADT 4267															
<i>Comments:</i>															



LOCATION: Pulehu Rd S of Hansen Rd SPECIFIC LOCATION: Pulehu Rd S of Hansen Rd CITY/STATE: Kula, HI							QC JOB #: 13803911 DIRECTION: NB/SB DATE: May 17 2016 - May 18 2016			
Start Time	Mon 17-May-16	Tue 18-May-16	Wed 18-May-16	Thu	Fri	Average Weekday Hourly Traffic	Sat	Sun	Average Week Hourly Traffic	Average Week Profile
12:00 AM		4	8			6			6	
1:00 AM		3	4			4			4	
2:00 AM		3	3			3			3	
3:00 AM		6	5			6			6	
4:00 AM		15	9			12			12	
5:00 AM		67	78			73			73	
6:00 AM		275	248			262			262	
7:00 AM		416	424			420			420	
8:00 AM		388	341			365			365	
9:00 AM		312	328			320			320	
10:00 AM		342	361			352			352	
11:00 AM		321	330			326			326	
12:00 PM		342	320			331			331	
1:00 PM		305	322			314			314	
2:00 PM		344	315			330			330	
3:00 PM		278	236			257			257	
4:00 PM		274	272			273			273	
5:00 PM		229	217			223			223	
6:00 PM		170	121			146			146	
7:00 PM		116	91			104			104	
8:00 PM		61	68			65			65	
9:00 PM		32	40			36			36	
10:00 PM		26	33			30			30	
11:00 PM		15	16			16			16	
Day Total		4344	4190			4274			4274	
% Weekday Average		101.6%	98.0%							
% Week Average		101.6%	98.0%			100.0%				
AM Peak Volume		7:00 AM 416	7:00 AM 424			7:00 AM 420			7:00 AM 420	
PM Peak Volume		2:00 PM 344	1:00 PM 322			12:00 PM 331			12:00 PM 331	
<i>Comments:</i>										